



DOWCO MARINE
STRONG INNOVATIVE SOLUTIONS

CELEBRATING
100 YEARS
EST. 1922
DOWCO



DOWCO
THE LEADER IN MARINE INNOVATION
— A PATRICK INDUSTRY COMPANY —

THE LEADER IN MARINE INNOVATION

IMPROVING FAMILY MEMORIES FOR 100 YEARS

CELEBRATING

100 YEARS
EST. 1922
DOVCO







COVERLIFT™

FOR ALUMINUM & FIBERGLASS
FISHING BOATS

THE ULTIMATE IN FAST & EASY COVER INSTALLATION

The patented CoverLift system is an innovative built-in cover support system that means no poles, no crawling under the cover, and no pole failures which can lead to cover or boat damage.

FEATURES:

- » Quick and easy to lock and unlock Gunnel-Lok™ fasteners (not incorporated into all CoverLift covers). Eliminates the need for snaps on the gunnels.
- » Protects the boat's interior from dirt, water, and UV light
- » Specifically engineered for trailering
- » Integrated vents allow moisture to escape while allowing the cover to compress while trailering - no cover flapping
- » Access panel with closures allow for cleat & fuel fill access
- » Constructed using Dowco's proprietary marine grade fabric. ClimaShield® Plus fabric is durable, water resistant, and breathable with excellent UV & fade resistance



COVER LIFT™ SYSTEM
*included on select
walk-thru models

DUAL PURPOSE
MOISTURE VENT / TRAVEL
VACUUM VENT

CLIMASHIELD PLUS
MARINE FABRIC

KICKER MOTOR
CUTOUTS

RATCHET
ACCESS POCKET

ACCESS PANELS
FOR CLEATS AND
FUEL ACCESS

PATENTED FASTENERS

Patented Gunnel-Lok™ fasteners for boat gunnel track systems.

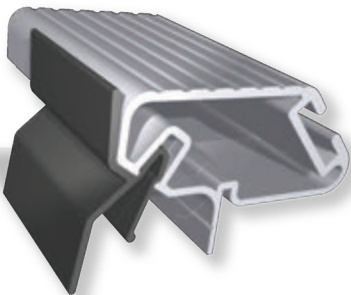

RATCHET POCKET

Constructed using premium EVA, this pocket protects the cover's ratcheting system while it's not in use.



CLEAT & GAS FILL POCKETS

Constructed using durable EVA material, cleat pockets ensure access to cleats around the boat or gas fill when the boat is covered.



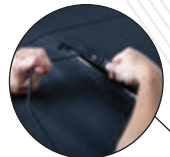

BUILT-IN RATCHET SUPPORT SYSTEM



GAIN ACCESS TO THE COVERLIFT SYSTEM, TO PUT THE SYSTEM INTO ACTION, TIGHTEN THE RATCHET FROM THE AFT OF THE BOAT.



OPTIONAL BOW COVER



STRAP CONNECTOR FASTENS OVER MOUNTING BUTTON TO SECURE COVER STRAPS



COVER SUPPORT SYSTEM

Lifting straps & ratchet are integrated into the cover.



COVERLIFT SYSTEM ENSURES WATER RUN-OFF

Straps create a raised tent effect to direct water runoff.



EASY TO INSTALL COVERLIFT STRAPS

Simply place the metal strap connectors located on the ends of the CoverLift straps over the mounting buttons fixed to the gunnel at the stern and bow deck for a secure, positive attachment. Open pocket at the bow or aft corners and tighten each ratchet.



PREMIUM COVERLIFT

SKI AND WAKE BOATS

Dowco's premium Coverlift cover systems are easy to deploy and provide superior boat protection over other leading brands. How did we do it? The key is our exclusive integrated center ratchet system. When the cover's ratchet is tightened, the cover rises into place creating a tented effect that prevents water from collecting or pooling. This innovative design vastly

improves watershed over conventional cover designs. Coverlift also eliminates the need for cumbersome poles and supports. Owners no longer need to uncomfortably crawl underneath the cover to install poles after the cover is installed.

INDUSTRY LEADING PATTERNING TECHNOLOGY

This beautifully contoured cover design enhances the boat's design and appearance by employing industry leading measuring processes and 3D geometric patterning practices.

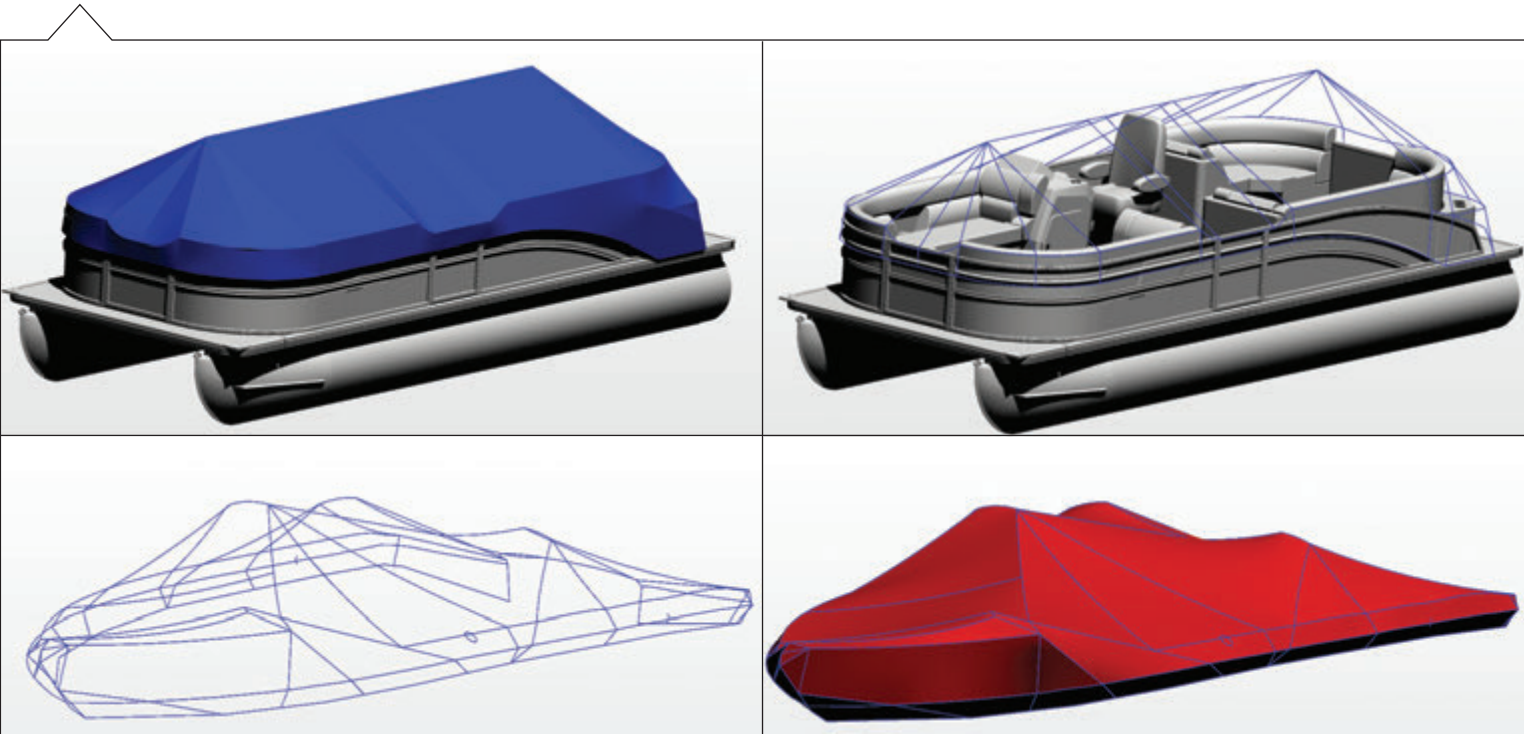

AN INNOVATIVE EXTERIOR
RATCHET SYSTEM CREATES
A SUPERIOR TENTING EFFECT
THAT ELIMINATES THE NEED
FOR POLES OR COMPLICATED
COVER SOLUTIONS

MOLDED EVA
POCKETS HOUSE
RATCHETS, FUEL
FILL, & CLEATS

CONSTRUCTED
USING PREMIUM
POLYESTER

DESIGNED USING
3D GEOMETRIC
PATTERNING

FIVE YEAR
PRO-RATED
WARRANTY



SECURED USING DOWCO'S
PROVEN RATCHET
FASTENING SYSTEM

SLEEK CONTOURED
COVER DESIGNS
ENHANCE THE BOATS
APPEARANCE

EVA POCKETS
PROVIDE ACCESS TO
BOAT CLEATS



ENCLOSURES

FOR ALUMINUM & FIBERGLASS
FISHING BOATS

SUPERIOR MARINE HARDWARE & FABRIC

Full enclosures on fishing boats are the perfect add-on accessory to a boat allowing fishermen to fish year round. Featuring durable, high quality, marine grade hardware, and fabric.

FEATURES:

- » Obstruction-free top design provides maximum headroom clearance providing improved fishability and unrestricted movement
- » Gasket sealed enclosure provides added water resistance
- » Stainless steel DowcoLok™ hardware securely mounts to the boat
- » Designs to clear boat gunnel for rod holders, downriggers, and other gear
- » 1.06" diameter heavy-duty framework - 30% stronger than typical framework
- » DowcoLok™ quick-release hardware makes install and removal fast & easy



STEP 1

DowcoLok™ hardware on the frame allows for mounting on top of gunnel or into gunnel track systems.

STEP 2

DowcoLok™ quick-release fastener locked securely to mounting button.

LOCKED-IN COVER SYSTEM

Bow tonneau cover and side curtains feature the Gunnel-Lok fasteners for boats with track systems.





a

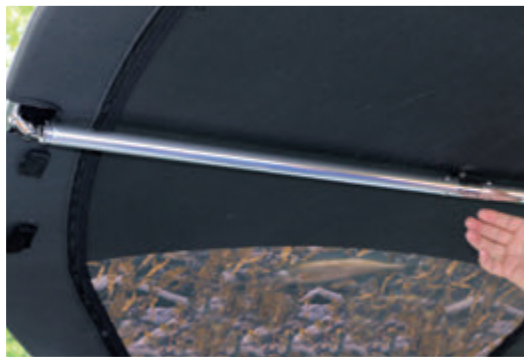

b

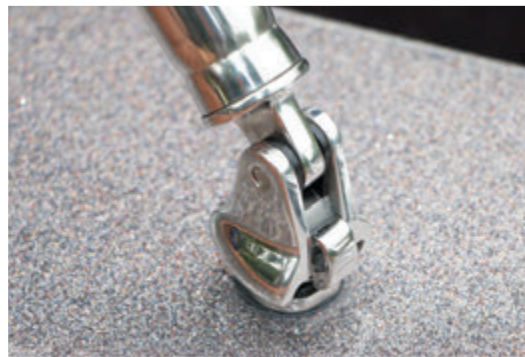

c



d

FISHINI™ TOP

FOR ALUMINUM & FIBERGLASS
FISHING BOATS

More than just a bimini. The Dowco Fishini combines the functionality and protection from the sun and the heat of a typical boat top, with added features to boost a boat's fishability.

FEATURES:

- a. Rods are stowed with easy-to-use hook & loop fasteners for the rod tips and elastic reinforcement for the rod handle
- b. Folding breakdown struts lock into place; stainless steel hinge construction provides more rigidity, added strength, and a quieter ride
- c. Features patented DowcoLok® stainless steel quick-release hardware
- d. Mesh pocket adds integrated storage for tools and gear that you need at your fingertips

- » Constructed using Dowco's marine grade ClimaShield Plus fabric
- » Available in multiple sizes
- » Higher clearance height than most tops



"RAD" HOLD-DOWN ARM FOR PONTOON BOAT CANOPIES



SCAN TO
LEARN MORE!

The Dowco RAD (Rapidly Adjustable Deployment) arm is an industry-first rapidly adjustable canopy system with 7" of adjustment. The system is designed to allow the end user to easily deploy the canopy with proper tension.

FEATURES:

- » The RAD arm takes the pain out of the deployment & tensioning of a pontoon canopy by allowing the user to secure the forward arm or struts to the boat first and then tension of by pulling down.
- » Typical canopies have fixed length struts, straps, or awkward telescoping devices that aren't exactly ergonomic or easy to use.
- » With the RAD arm the user simply attaches the forward strut to the boat with the canopy under no tension and then with both hands and proper body position tension is easily applied to the canopy.



SAY GOODBYE TO PINCHED FINGERS AND DIFFICULT TO SECURE BIMINIS. DOWCO'S RAD HOLD-DOWN ARM SECURES WITH A SIMPLE PULL DOWN AND RELEASES WITH THE CLICK OF A BUTTON.



EASYLIFT™

**FOR PONTOON
BOAT CANOPIES**

Raising your bimini top has never been easier. With Dowco's exclusive EasyLift™ canopy system, simply release the handle holding the stowed bimini top to the rail and the top deploys with little effort. Built-in gas springs do all the lifting for you. To stow, simply release the lock handle and lower the canopy back to the rail where it fastens securely for running or transport.

EasyLift is available in multiple different sizes, from 7'-13', and powder coated frame colors including black and black anodized



STEP 1

Attractive EasyLift hardware holds your bimini top in place.



STEP 2

Release EasyLift handle from its locked position.



STEP 3

Gently raise the canopy with very little effort to deploy.



POWDER COAT FINISH OPTIONS

Boat builders today offer a variety of colors and finishes for canopies.



RAIL-LOK PX PONTOON BOAT COVERS

A BETTER WAY TO COVER PONTOON BOATS

This custom-fit pontoon cover system features unique PX clip fasteners that lock into the receiver slot under the middle rail extrusion on the pontoon's fence. These patented fasteners are engineered to lock and unlock with a simple squeeze of the fastener. Spaced strategically around the edges of the cover, the system delivers a tight and secure locked-in cover eliminating hard-to-use snaps.

PONTOON MOORING COVERS:

- » Designed to fit most pontoon sizes
- » Protects your pontoon when docked
- » Includes adjustable poles for increased water run-off

PATENT PENDING FASTENER

Simply insert the cover's Rail-Lok™ PX fastener into the pontoon's receiver slot.

LOCKED-IN COVER SYSTEM

When engaged, the patented system locks the cover firmly into place. Removing the cover is just as easy.

EASY & SECURE

Inserting the Rail-Lok™ PX fastener into the receiver slot eliminates the need for awkward and difficult to use snaps.



DUAL PURPOSE
MOISTURE
VENT / TRAVEL
VACUUM VENT



POLE SYSTEM WITH
OPTIONAL FOOT PAD AND
HEAVY DUTY CAM LOCK

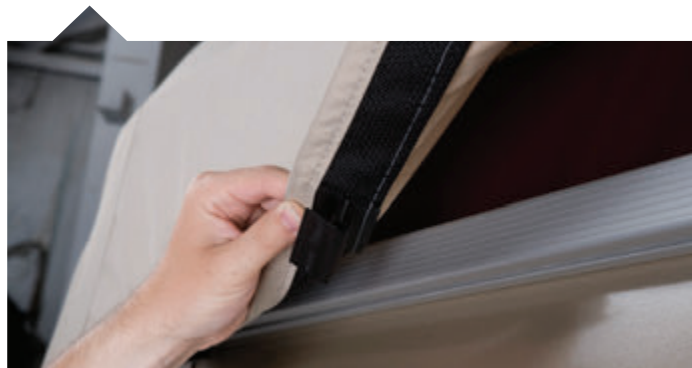
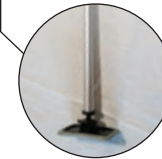

RAIL-LOK HC

PONTOON BOAT COVERS

THE ULTIMATE IN FAST & EASY PONTOON COVER INSTALLATION

The Rail-Lok™ HC cover is the first towable pontoon cover available in the market. This custom-fit pontoon cover system features unique fasteners that lock into the receiver slot under the middle rail extrusion on the pontoon's fence. These patented fasteners are engineered to lock and unlock with a simple twist of each fastener. Spaced strategically around the edges of the cover, the system delivers a tight and secure locked-in cover eliminating hard-to-use snaps.



PATENT PENDING FASTENER

Simply insert the cover's Rail-Lok™ HC fastener into the pontoon's receiver slot.

LOCKED-IN COVER SYSTEM

When engaged, the patented system locks the cover firmly into place. Removing the cover is just as easy.

EASY & SECURE

Inserting the Rail-Lok™ HC fastener into the receiver slot eliminates the need for awkward and difficult to use snaps.

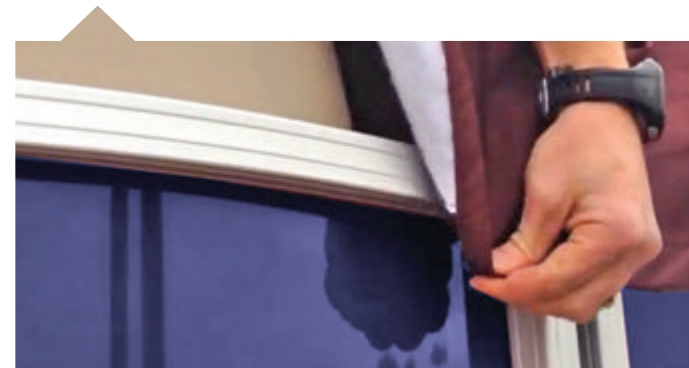
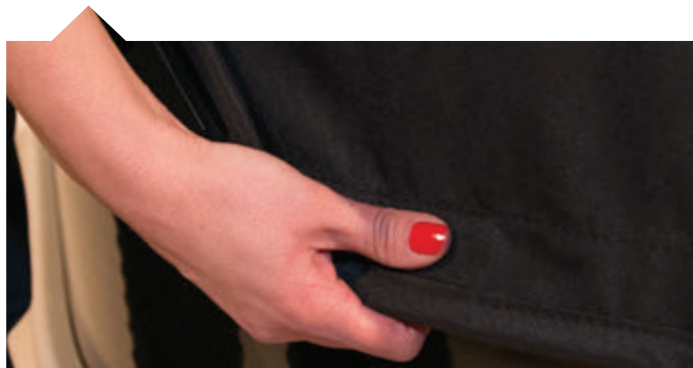
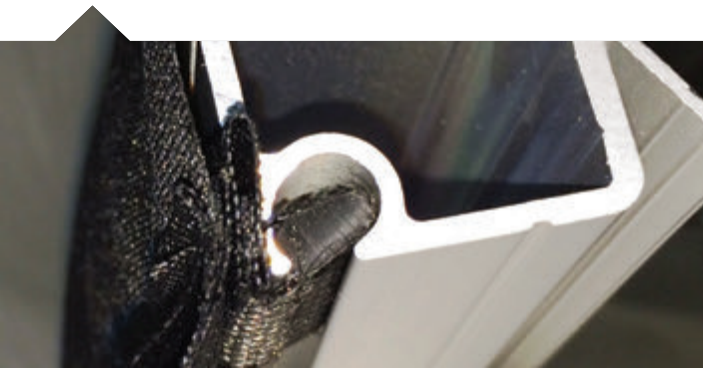



HIGH-SPEED BIMINI TOP

FOR PONTOON BOATS

New for model year 2022, Dowco's High Speed Bimini Top: a radical departure from the everyday bimini. Pontoon boats are trending towards yacht-like appearances, added power, and increased performance. The new top is built to withstand the wind resistance and vibrational forces of today's more powerful pontoons while elevating its overall appearance.

The High Speed Bimini Top is an improved approach to the pontoon canopy frame / canvas top systems that is strong enough to withstand speeds of up to 60 MPH wind speed both securely and with minimal vibration. Accented with sleek European styling, its aerodynamic design is distinctive and gives any pontoon an enhanced first impression. With construction that combines high-strength extruded aluminum and superior materials, the top is the perfect choice for performance sport pontoons, tri-pontoons, or luxury pontoons. The High-Speed Bimini Top also features Dowco's exclusive EasyLift™ technology. An NMMA Innovation Award winner, EasyLift allows the bimini to deploy and stow with considerably less effort. Secured with performance-matched hinges and fasteners, the High-Speed Bimini Top provides a premium upgrade and price point opportunity that consumers will immediately acknowledge.

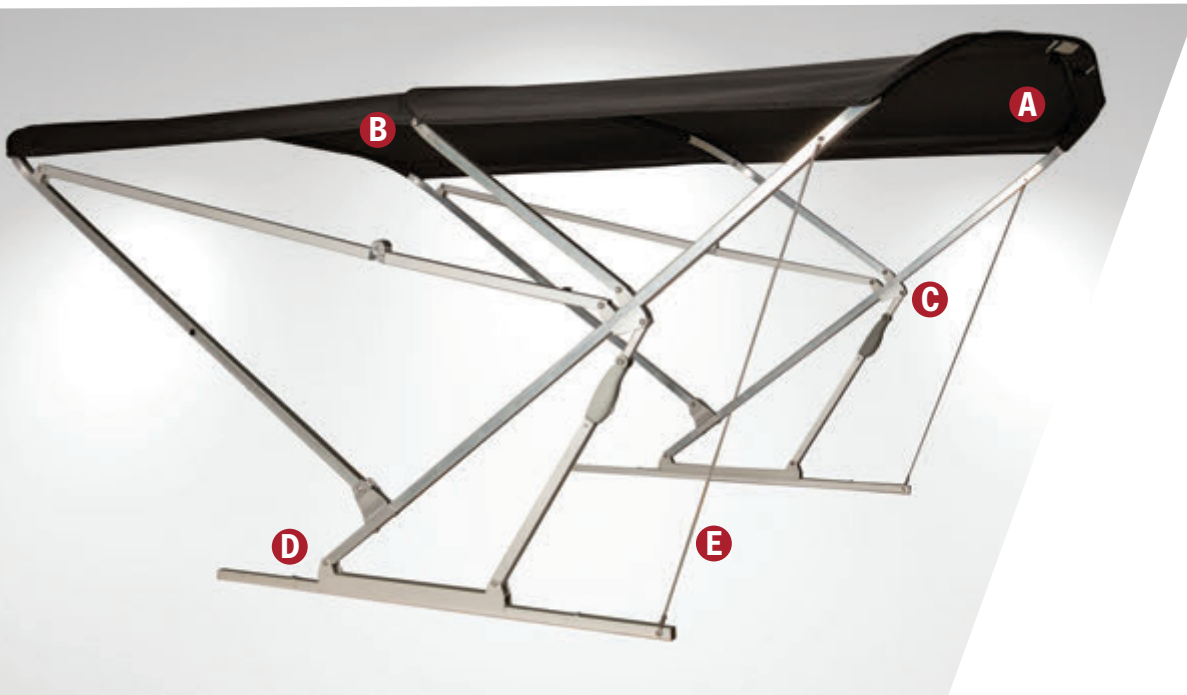

FEATURES:

- A** Industry-leading ClimaShield® Marine-Grade Fabric
- B** Easy-to-access zip in, zip out frame pocket
- C** No-pinch EasyLift™ deployment / stow system
- D** Universal mounting bracket fits pontoon
- E** Support cable stabilizes the bimini without adding weight

POWDERCOAT COLOR OPTIONS:

-  Bronze
-  Black
-  White
-  Starlight Gray
-  Starlight Charcoal



WINNER OF
2015 IBEX
INNOVATION
AWARD



**AWARD-WINNING
EASYLIFT™ SYSTEM**

**PREMIUM CLIMASHIELD®
WATER RESISTANT FABRIC**

**HEAVY DUTY AIRCRAFT-GRADE
ALUMINUM MILLED JOINTS**

**RETRACTS CONVENIENTLY INTO
A COMPACT ENVELOPE**



**BUILT
FOR SPEED**



**PREMIUM
MATERIALS**



**MADE IN
THE USA**



**BEST IN CLASS
WARRANTY**

HIGH SPEED BIMINI TOP OVERVIEW

- » Hinges lock on deployment
- » Rated to 60 MPH wind speed
- » EasyLift design assist for easy storage and deployment
- » Same footprint as traditional Biminis
- » 11 foot coverage
- » No additional/special installation required
- » No additional straps to the fence, gives options for placement, gives clearance near side doors
- » Easy deployment and access to releases

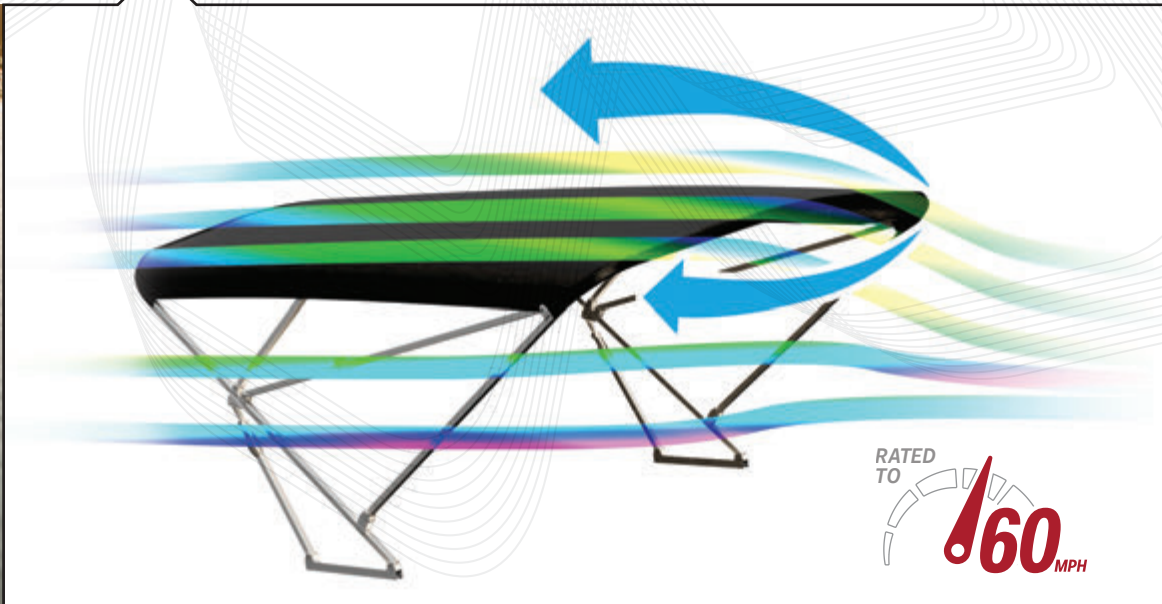

RATED
TO
60
MPH



IN-HOUSE DESIGN CAPABILITIES

PONTOON FURNITURE & SEATING

**“DESIGN IS NOT JUST WHAT IT LOOKS AND FEELS LIKE.
DESIGN IS HOW IT WORKS.”**

—STEVE JOBS

DESIGN:

- » In-house design team
- » Facilitate the whole design process with full project support, from start to finish
- » Ability to design based off defined specs or from a clean slate
- » Our design team and sales team work side by side with our customers, every step of the way
- » Complete design renderings

FOAM:

- » We can design, develop, prototype foam profiles
- » We design for basic ergonomics
- » Expertly designed foam pairs perfectly with the style of boat, and the customer's preferences

VINYL:

- » We have designers on staff to help choose color and feel of a boat
- » We stay up to date with color and trends to help develop a style both unique to the manufacturer and relevant to the boat owning public
- » In-house CNC quilting and embroidery capabilities

ROTO:

Dowco designs pontoon furniture to uniquely and creatively fit our customer's needs.
We have over 28 rotomolded seat bases we use to design pontoon furniture layouts.

PRODUCT LINE:

- » We offer a full line of rotomolded seat bases
- » 2 different size corner sections (29" and 31" Radius)
- » Full range of foam in both biocide and standard formulation
- » Offer several different style seat pans (Wood, HDPE, Vacuum Form ABS)

SPECIALTY PIECES:

- » In-house design and engineering for specialty products
- » Complete design and prototyping

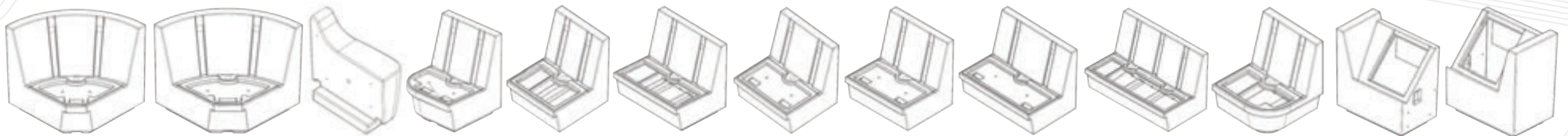

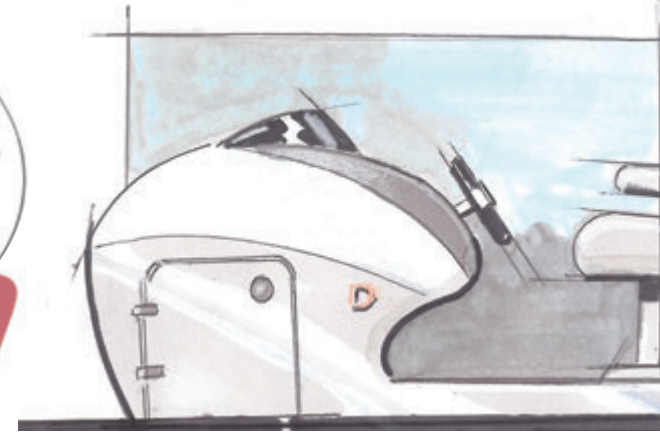
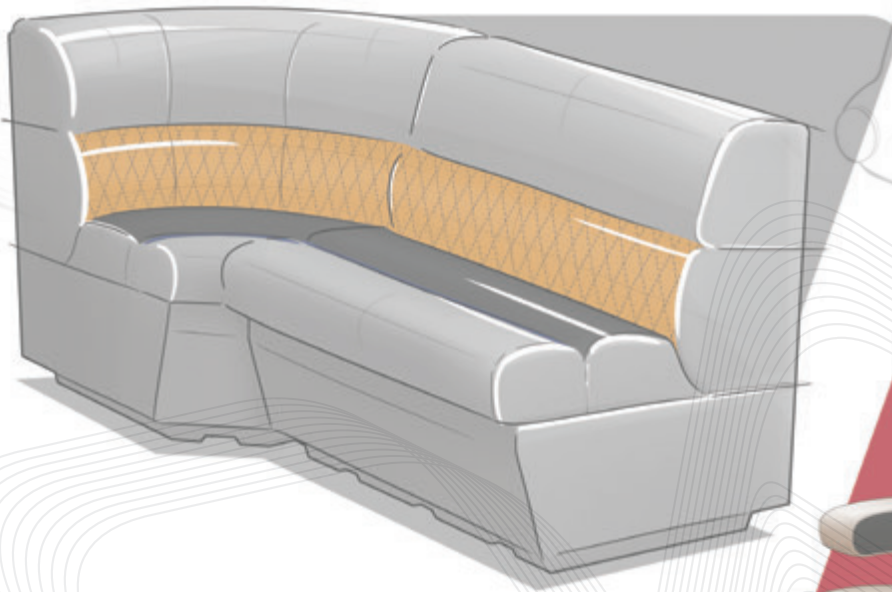

ADJUSTED POSITION

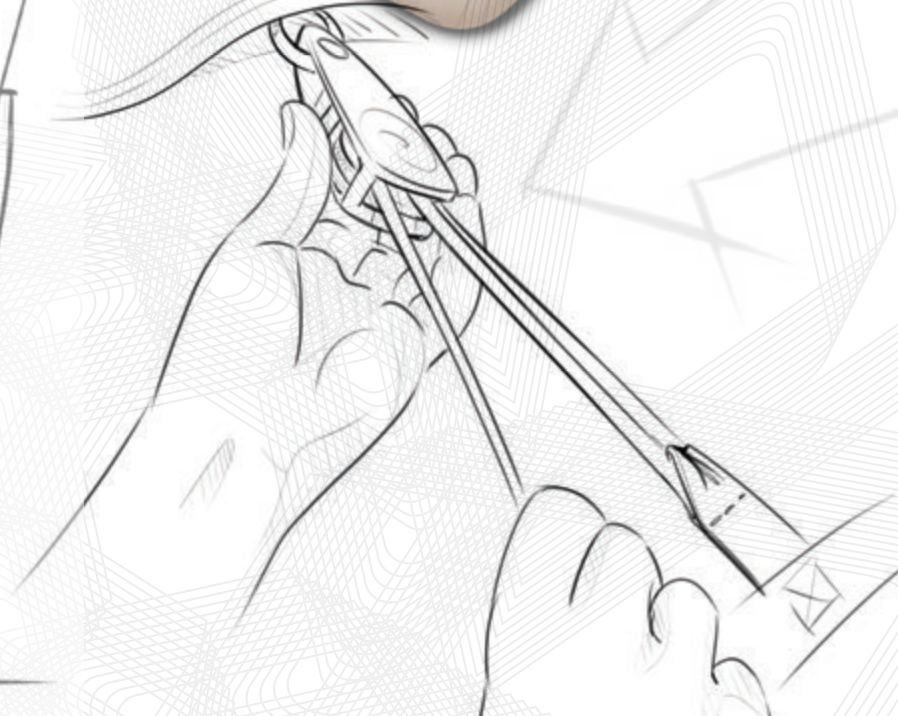



MARINE FURNITURE

For nearly a century, the Dowco name has been an innovative force in the industry, developing some of the most ingenious and award-winning products in marine hardware, covers, and accessories.

Dowco furniture is carefully hand-crafted and designed to compliment the characteristics of the boat it will reside on. All pieces are manufactured in the US, throughout Dowco's multiple manufacturing locations strategically located in WI, MO, and IN.

Full-service design and development team leads process, from initial concept phases through final production phases.

FURNITURE FEATURES:

- » *Industry leader in cut & sew, and design & styling capabilities*
- » *High quality upholstery formed around Dowco's rotational molded seat bases*
- » *Form, fit, and function is our design priority with built-in storage areas*
- » *Multiple density, comfortable foam layers*
- » *Hand picked premium materials that have been tested and proved to stand up in harsh marine environments*





HELM CHAIRS
TO COMPLIMENT
FURNITURE OFFERING





CRUISEAIR

**SHOCK ABSORPTION
FISHING BOAT SEAT SYSTEM**

AN ALL-NEW FULLY-ADJUSTABLE AIR SUSPENSION SEAT

Dowco Marine's patented boat suspension seat maximizes comfort and on-water performance. CruiseAir™ is reshaping the way fishermen and boaters think about their seating needs!

As the leader in marine innovation, we set out to improve comfort, functionality, and safety in boat seating. Our goal was to design a fully-customizable and amazingly comfortable seat. The only "shock absorption" seat with integrated adjustable seat base and back, CruiseAir is quickly becoming the choice of champions.

State-of-the-art marine seat system, designed to allow the rider to inflate or deflate the seat system, consists of air bladders that are built into the base and back of the seat. By simply pressing the inflate or deflate button on the side of the seat, the seat will be inflated within 10 seconds, putting the rider into their desired position. Intended to add security and safety, while putting the rider into the most comfortable riding position for them.



KEY CONSUMER FEATURES

- » Safe & secure riding position
- » Adjustable on the fly
- » Up to 6" adjustability in back and 4" in seat base
- » Customizable to all body sizes & shapes
- » Increases safety
- » Fish longer in comfort
- » Reduces the effects of running a boat in rough water

KEY OEM FEATURES

- » Game-changing technology
- » First-to-market product
- » Patented
- » Fully-customizable
- » Position focused
- » Water shedding, marine grade materials
- » Designed to increase safety
- » Tested, validated
- » Turn-key for OEMs and consumers alike
- » High acceptance rates among OEMs
- » 2 year warranty



CRUISEAIR
AFTERMARKET SEAT

Pro Fisherman Ott DeFoe knows what it takes to compete for long hours at peak performance. Below, Ott demonstrates a typical seating position with CruiseAir's backrest relaxed vs. fully extended.



OTT DEFOE
FISHING PRO

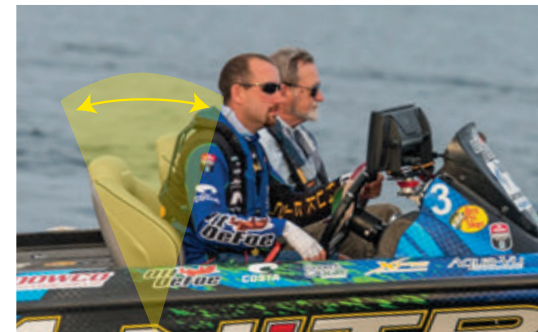

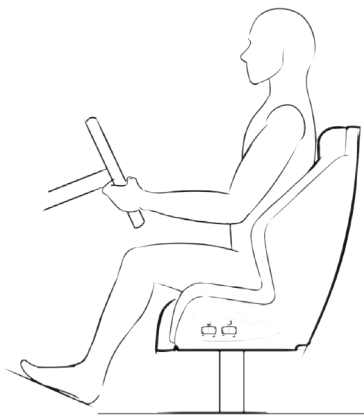

NORMAL POSITION



ADJUSTED POSITION

- 1 Superior construction. Durable materials.
- 2 Adjustable beyond 90°
- 3 Stylish integrated furniture & features
- 4 Fully inflates/deflates in 10 seconds
- 5 Water resistant pump and waterproof switches
- 6 Adaptable to bass, pedestal, bench, and helm seats



With the touch of a finger, seat angle and cushion pressure can quickly be adjusted.



CruiseAir quickly and easily adjusts to a wide range of motion for both the fisherman's driving position and body dynamics. Typical fishboat seats only accommodate the driver's position at idle and low speeds.



SCAN TO LEARN MORE!

A state-of-the-art system for manufacturing and building pontoons, designed for boat builders to implement into their existing manufacturing process. The system replaces the aluminum or fiberglass fence structure with the Nextoon system, constructed in a pod and delivered ready to be plugged into the boat building process.

REINVENTING PONTOONS WITH SUPERIOR DESIGN & MATERIALS

Compare traditional pontoon manufacturing processes to Nextoon's advanced construction & finishes:



ALUMINUM:

- » is a louder ride.
- » is prone to denting & marring.
- » is more labor intensive.
- » requires more skilled labor.
- » takes longer to install.
- » is limited to 2D.
- » has limited styling options.
- » requires 3rd party supplier to achieve additional styling (anodizing or powdercoating).
- » fluctuates more in cost.
- » is subject to volatile metal costs.

FIBERGLASS:

- » is more expensive.
- » is slower to produce. One unit, per tool, per day.
- » is more prone to marring and scratches.
- » is heavier.
- » is much more expensive to replace.
- » is capital intensive.
- » is difficult to store. (Parts do not nest together, takes up a lot of space.)
- » is difficult to ship.

EVERYONE BENEFITS

The Nextoon pre-configured pontoon system is a revolutionary concept that brings contemporary design opportunities, improved materials, and incredible manufacturing efficiencies to the pontoon industry. Engineered with numerous patented features, Nextoon provides benefits to consumers, dealers, and OEMs alike.

CONSUMER:

- » Lightweight
 - » Easy to repair if needed
 - » Customizable, or can be bought as a kit to refurbish old boats
- ### DEALER:
- » Upgraded design & styling
 - » Easy to repair
 - » Higher margin and better price points
 - » Differentiation - can offer a rebuild pontoon program

OEM:

- » Higher margin and better price points
- » Differentiation, can offer a rebuild pontoon program
- » Easy to install - using a more readily available workforce
- » Resolves issues of space constraints - parts nest together for easy storage
- » Cost effective - one tool can make a part every 10 min
- » Space savings
- » Reduction in capital
- » Reduce bottlenecks of traditional aluminum or fiberglass fencing



	ALUMINUM	FIBERGLASS	NEXTTOON
MATERIAL & LABOR COST	Moderate	High	Low
LIGHT-WEIGHT	Light	Heavy	Light
CUSTOMIZABLE	2 dimensional	3 dimensional	3 dimensional
PRODUCTION TIME	High Labor Cost (Throughput bottleneck)	Low Output (High Cost)	High Output (Low Labor Cost)
CUSTOMER PERCEPTION	Non-Differentiated (boring)	Too Expensive (high cost)	The Solution (higher value)



SCAN TO LEARN MORE!

- 1 Trend-setting boat design solutions in trending colors & finishes
- 2 Durable components
- 3 Stylish integrated furniture and extra unique design features
- 4 Integrated retractable cover + storage
- 5 Integrated bimini top + storage
- 6 Integrated navigational lights
- 7 Integrated interior LED lighting, USB ports, stereo speakers, beverage holders, and more
- 8 Under-seat dry storage and cooler spaces
- 9 Integrated front, side, and rear gates
- 10 Professional-grade production: meets or exceeds ABYC, NMMA, and US Coast Guard testing standards

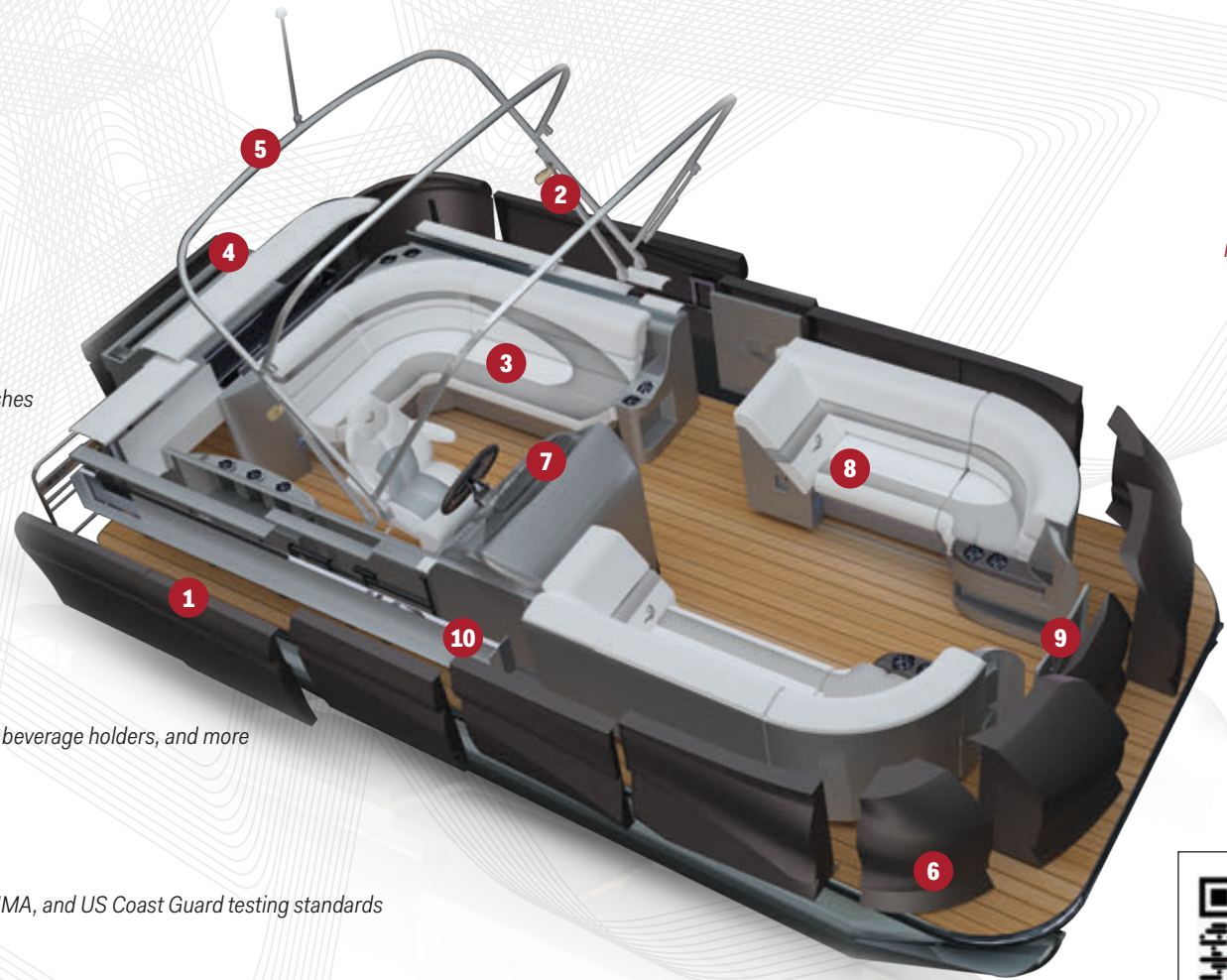

SCAN TO LEARN MORE!

FURNITURE DESIGN PARTNERSHIP

Collaborate with Dowco's design team to design & build furniture the way you've always wanted it to be. Shape, style, function, color... if you can think it we can do it.

RETRACTABLE COVER STORAGE

An industry first, a retractable cover system that stows within the boat's cavity. Take away the issues of where to store the cover while it's not in use, or fumbling around with it to figure out which end is the front.

INTEGRATED STOWABLE BIMINI

Stow your bimini in the cavity of your boat when not in use. Another industry first.

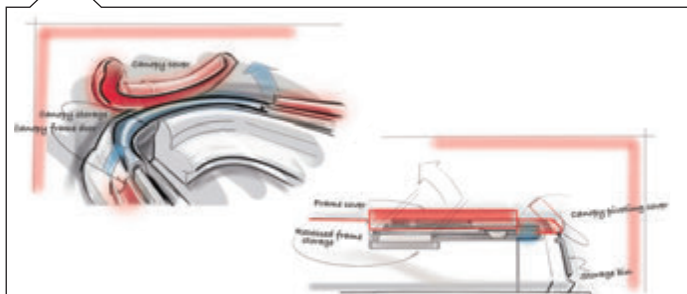
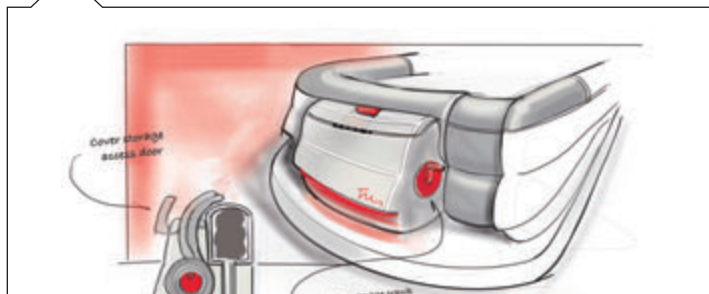



HARDWARE ACCESSORIES

FOR FISHBOATS & PONTOONS

Dowco designs & fabricates both round & square tube bimini frames to match specific requirements. Available in stainless steel, aluminum, or our most recent launch, composite. We are equipped to create traditional designs or a customized design to match the appearance or features of a specific boat. Dowco finds pride in meeting your needs. Trust us as your single source for innovation in form, fit, finish, and function.



DOWCO RATCHET



DOWCOLOK®
STAINLESS STEEL



DOWCOLOK®
COMPOSITE



TOOL HOLDER



HEAVY DUTY ROPE
RATCHET SYSTEM



DRINK HOLDER



TACKLE BOX



VERSA TRACK
BRACKET WITH
DECK BUTTON



TELESCOPING
BREAKDOWN HINGE
COMPOSITE



BREAKDOWN HINGE
STAINLESS STEEL



STAINLESS STEEL
SWIVEL



ADJUSTABLE
EYE END



PIVOT / PIVOTING
EYE END



RAIL-LOK™ PX

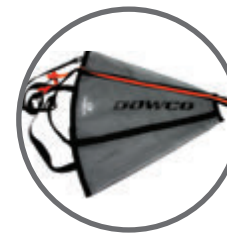

DRIFT SOCK



FENDER HANGER
SYSTEM

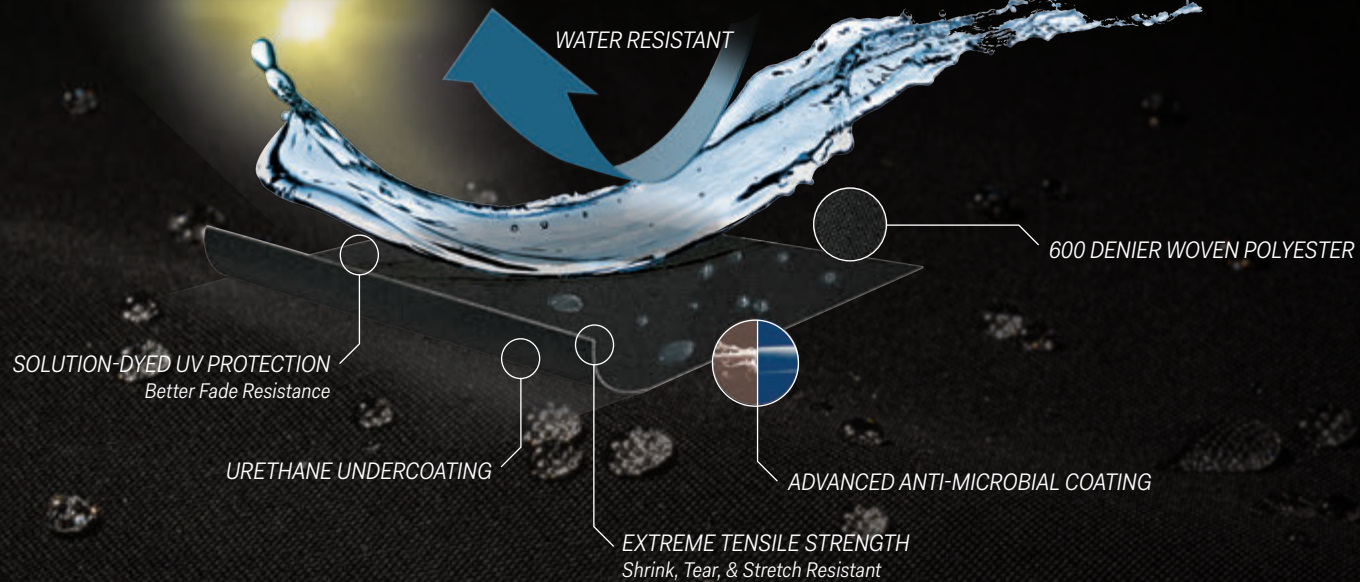

2X STRONGER & 3X MORE WATER-RESISTANT THAN THE COMPETITION!

- » The ideal fabric for boat covers, tops, and enclosures
- » 7.5oz 600 denier solution-dyed polyester fabric
- » Provides superior UV protection and fade resistance
- » Enhanced with Durable Water Repellent (DWR)
- » Urethane undercoating increases longevity & durability
- » Highly resistant to mold & mildew (anti-microbial coating)
- » Engineered to resist shrinking or stretching



DEVELOPED FOR HARSH MARINE CONDITIONS

- » Preferred material for tops & enclosures for harsh marine environments
- » Heavy-duty, 10.7oz. 600 denier polyester fabric
- » Waterproof with polyurethane top and under coatings
- » High tensile strength and tear resistant
- » Engineered to resist shrinking & stretching

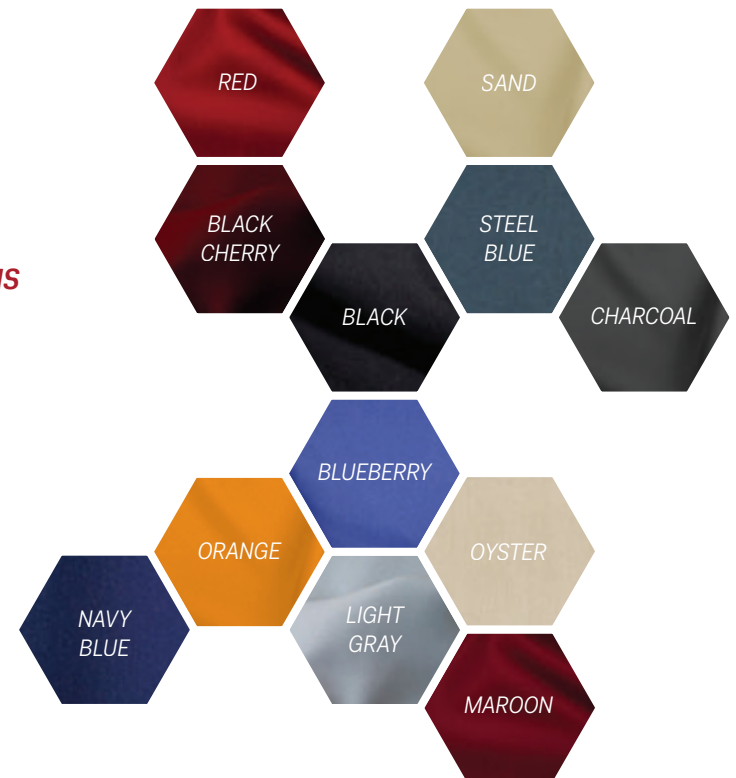



MORE THAN JUST A MARINE COMPANY

DOWCO MARINE

YOUR INNOVATION PARTNERS

Dowco® (a division of Patrick Industries) is a committed manufacturer that places considerable investment in research & development to pursue new ways to develop innovative products. At Dowco, customers are the core of everything we do. That's why we are focused on learning so we can continue to deliver quality, great service, and reliability. Our success is a direct result of our people and their quest to meet & exceed your needs. We have 250 employees ready to serve you.

OUR HISTORY

In 1922, Dowco started designing & manufacturing products for the tent & awning industry. Today, we have evolved into a global leader servicing a variety of industries with a focus on cut & sew and plastic products for the marine and boat industries. Our capabilities include design, manufacturing, and sourcing textile & covers, bimini tops, and hardware for the recreational marine market and OEM products.

SUPPORTING PARTNERS

Dowco produces marine covers, tops, hardware, and furniture for a wide variety of boat manufacturers. Using the highest quality marine components, Dowco is the supplier to most of the leading boat brands, including Tracker, Mako, Premier, Alumacraft, Lowe, G3, Harris, Smoker Craft, PlayCraft, Landau, Barletta, Warrior, and other major boating manufacturers.

Dowco is committed to bringing the best products to market and continued high levels of service to the industries we serve. Our continued growth is a result of having a dedicated team of over 300 individuals that make our customer's businesses our own.

A DIVISION OF PATRICK INDUSTRIES, INC.

As of May 31, 2018, Patrick Industries has completed the acquisition of Dowco, Inc. ("Dowco"), a designer and manufacturer of custom designed boat covers and bimini tops, full boat enclosures, mounting hardware, and other accessories & components for the marine market, from CMW Holding Company. Patrick Industries, Inc. is a major manufacturer of component products and distributor of building products serving the recreational vehicle, manufactured housing, marine, kitchen cabinet, office & household furniture, fixtures, commercial furnishings, and other industrial markets and operates coast-to-coast through locations in 21 states and in China.

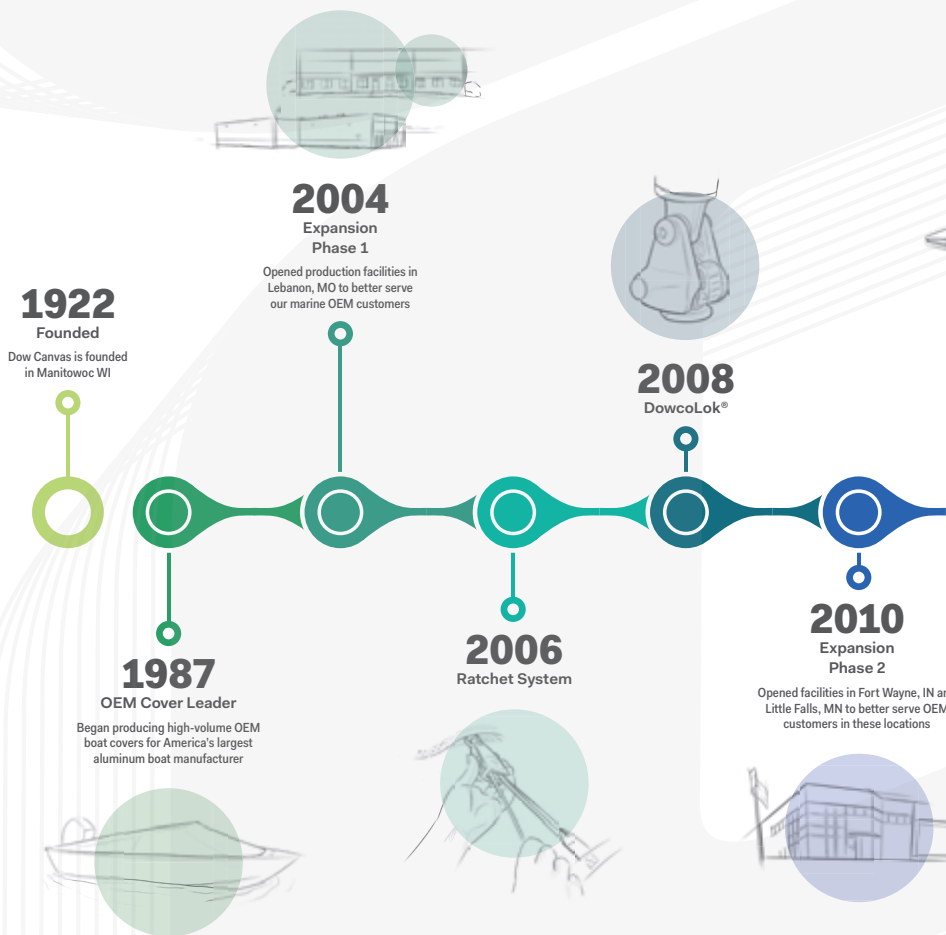



2014
Rail-Lok™ PX &
Rail-Lok™ HC

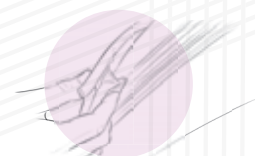

January
2015
Gunnel-Lok™



April
2016
Plastics Leader
Acquired Premier Plastics and Leisure
Designs of Hoyt Lakes, MN

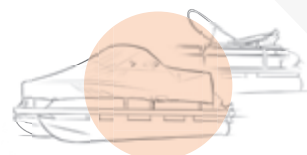

February
2017
Universal
Pontoon Cover



May
2018
Patrick Industries
Acquires Dowco Marine



Spring
2019
CruiseAir

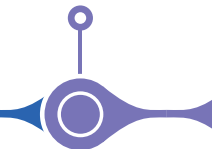

January
2015
CoverLift™



September
2015
EasyLift™
Winner of the 2015
IBEX Innovation Award

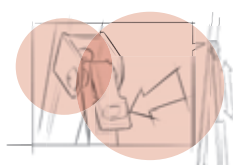

May
2016
Ratchet Hold-Down Arm

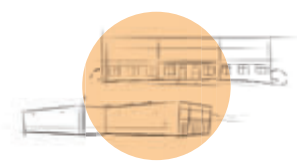

February
2018
Lebanon, MO Facility
Expansion of 25,000 square feet



September
2018
Nextoon
Unveiled at IBEX



2022
Dowco Celebrates
100 years

DOWCOMARINE.COM

THE LEADER IN MARINE INNOVATION

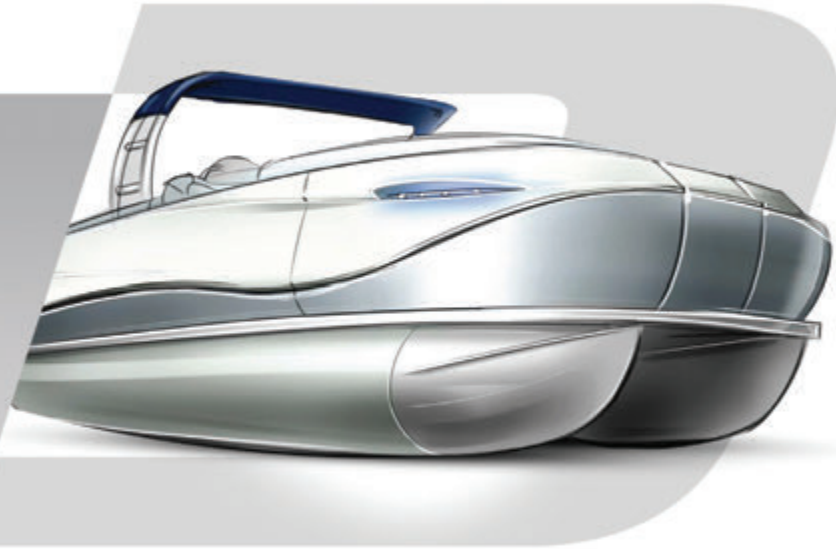

OUR MISSION

Our mission is to create products that are superior in design, quality, and value to create loyal customers. We will work to achieve the industry's highest levels of employee & customer satisfaction. We will strive to achieve a level of earnings & growth to allow for aggressive reinvestment in our facilities, people, and products.

OUR VISION

Dowco will become the leading supplier serving the needs of our chosen markets by developing complimentary new competencies & products with and for our customers.

OUR COMPETENCY STATEMENT

Development of integrated product solutions for our customers, using the most efficient sourcing & manufacturing options, delivered to our customers in the model of an extension of their own operation's proximity, partnering, and value.



LOCATED NEAR YOU

Our strategic locations put Dowco representatives near our clients to provide them superior design, product, and service.

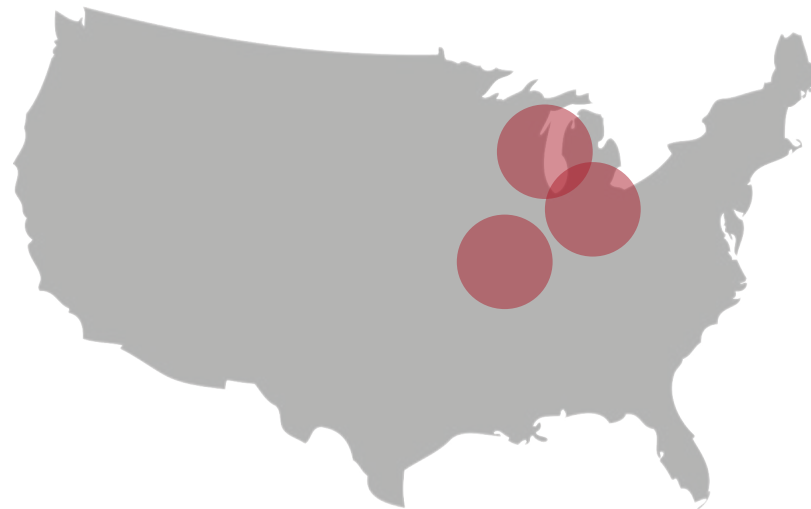

MANITOWOC, WI

LEBANON, MO

FORT WAYNE, IN