

INSTALLATION INSTRUCTIONS

2016-2019 Double Canopy / Full Enclosure

Tracker Marine Fishin Barge 24 DLX Signature

PARTS LIST

DOUBLE CANOPY:

1 Bow Canopy
 1 Bow Canopy Boot
 1 Aft Canopy with Front Zipper
 1 Hardware Package
 1 Bow Frame

FULL ENCLOSURE:

Aft Canopy w/Zipper
 1 Hardware Package
 1 Aft Curtain
 1 Bow Canopy w/Zipper
 2 Aft Side Curtains (1 Port, 1 Starboard)
 2 Bow Side Curtains (1 Port, 1 Starboard)
 1 Bow Curtain
 1 Bow Frame

TOOLS REQUIRED

Measuring Tape
 Center Punch
 Drill
 $\frac{23}{64}$ " Drill Bit
 Pencil
 Phillips Screwdriver
 Crescent Wrench



WARNING

INDICATES POTENTIAL HAZARD
 THAT COULD RESULT IN DEATH
 OR INJURY



CAUTION

INDICATES POTENTIAL
 HAZARD THAT COULD
 RESULT IN BOAT DAMAGE



NOTE

INDICATES SPECIAL INFORMATION
 TO MAKE MAINTENANCE EASIER
 OR INSTRUCTIONS CLEARER



NOTE:

This enclosure is designed to fit the 2016-19 Tracker Marine Fishin Barge 24 DLX Signature Pontoon Boat that has the aft canopy brackets, deck buttons, and eye straps in the following locations:

Main Aft Bracket 134"

Forward Aft Eye Strap 33 1/2"

Measurements should be taken from back of fence for Aft Canopy Brackets and as shown below for bow canopy brackets and buttons in the following locations:

Aft Pivot to Bow Main 95"

Bow Main to Hold-down Arm 27"

If the brackets are off more than 1 inch in either direction, the enclosure WILL NOT FIT.

FIG. 1

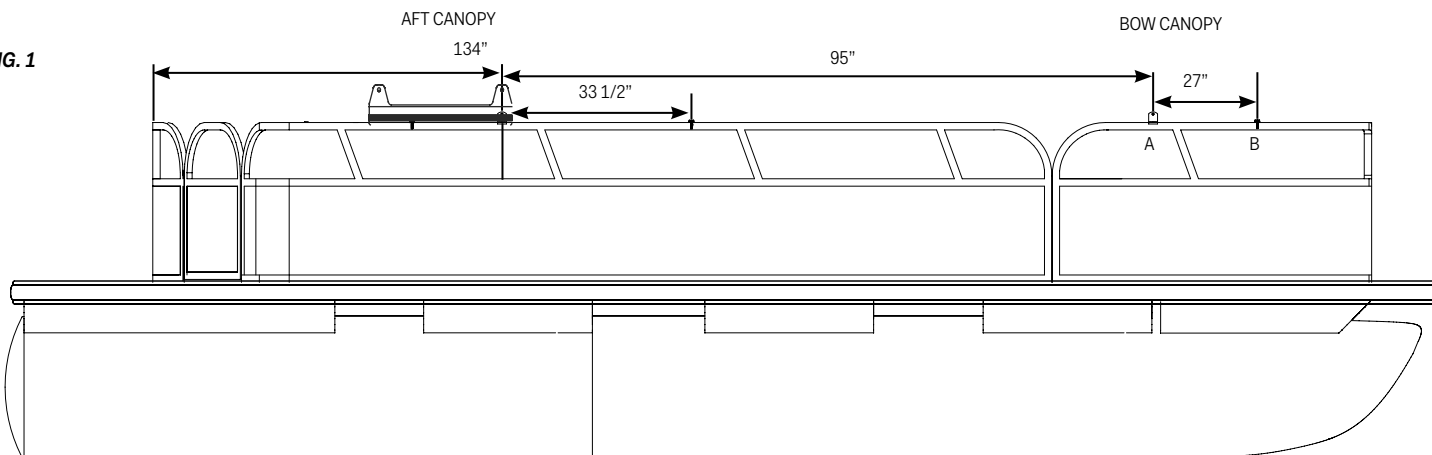

NOTE:

Your pontoon has been pre-assembled with an aft canopy and aft canopy frame from Tracker Marine. The aft canopy that is supplied with the pontoon is not designed to be used with an enclosure. You must remove the standard aft canopy and replace it with the aft canopy that is supplied with the purchase of your enclosure. Once the new canopy is installed, raise the entire unit to the "up" position. Make sure the aft canopy is centered on the frame between the port and starboard sides. This step is very critical, it will determine the final appearance of your completed enclosure.

BRACKET LOCATIONS & ASSEMBLY (FIGURES 1 & 2)

STEP 1

Bracket location (A). Measure and place a mark on the top rail 95" forward from aft main bracket. Bracket location (B). Measure and place a mark on the top rail 27" forward from (A).

STEP 2

Center the brackets and deck buttons at each mark as shown in Figure 2. Transfer the centers of each hole at the bottom of the bracket and deck button on to the rail using a center punch.

STEP 3

Using 2 1/4" drill bit, drill holes completely through the top rail.

STEP 4

Replace the brackets. Insert (2) bolts from the bottom through the bracket and the rail. Place (2) lock nuts on and tighten (Figure 2).

STEP 5

Install deck buttons at location (B) using barrel nuts.

STEP 6

Follow the same procedure for the other side.

FIG. 2

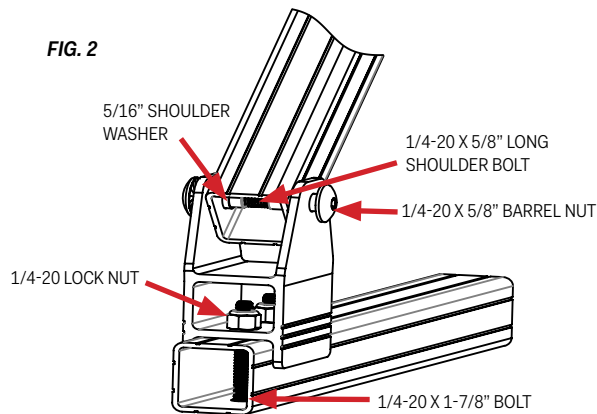

CAUTION

TO PREVENT DAMAGE TO THE TOP RAIL, IT IS RECOMMENDED TO DRILL A PILOT HOLE FIRST.

FIG. 5

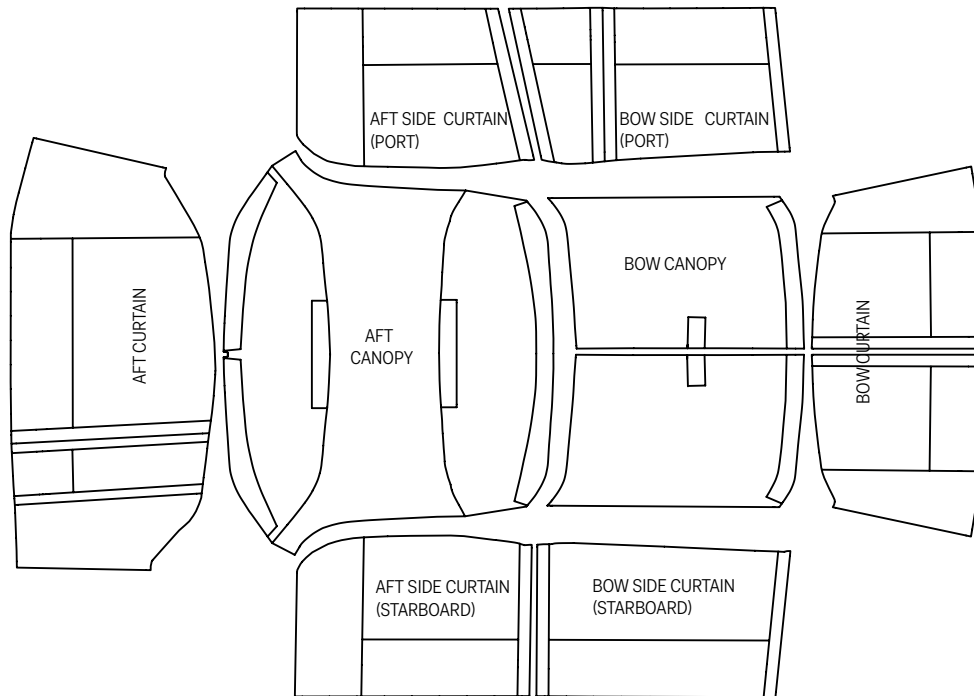

CURTAINS (FIGURE 4)

STEP 1

Each curtain has a tag sewn in the upper left-hand corner of the flap. This will identify each curtain and give its location on the pontoon.

STEP 2

The curtain flaps will face the inside of the pontoon.

STEP 3

Start with the Bow and Aft curtains. Zip approximately 6" of the Aft curtain to the top. Insert the RailLok HC clips in the rail and slide them down the rail as you insert them. Finish zipping the curtain to the top. Repeat this process for the Bow curtain and side curtains.

STEP 4

Finally zip all curtains together.

STEP 5

To remove the curtains unzip all of the curtains, then unzip each curtain from the top. That will release the tension to remove the RailLok HC clips from the rail.



NOTE

THIS IS A FLOATING SYSTEM AND CAN BE SHIFTED ALONG THE RAIL FOR BETTER FIT IF NEEDED.